



GREEN BOAT PROJECT *Hybrid Propulsion System and Alternative Fuels*

The most innovative aspect of RiverQuest's *Explorer* is the propulsion system. After a thorough evaluation of existing technology by the industry's leading alternative fuel marine engineers, Alion JJMA, the designers of the yet-to-be-built San Francisco Bay Area Water Transit Authority Fuel Cell Ferry, it was determined that a diesel-electric hybrid system was the best alternative. The flexibility and exceptional environmental performance of this design is coupled with high reliability and proven technology.

***Explorer* is one of the first vessels in the world constructed with this propulsion system design.**

The hybrid propulsion system provided by Siemens Energy and Automation is among the world's most advanced diesel-electric power generation technologies. The engines will run on a biodiesel fuel blend and the system explicitly provides for the future addition of new power sources such as a fuel cell, solar panels and micro wind turbines. **The organization's reliance on imported oil will be significantly reduced through the use of domestic biodiesel.**

Explorer will reduce the total energy needed by the RiverQuest fleet to serve 10,000 students by over 35,000 kW-hrs per year or nearly 50%. Emissions of CO₂, SO_x and PM will be significantly reduced.

www.RiverQuest.org
412.231.2712

The design and construction of RiverQuest's green boat *Explorer* represents a significant national and international step for green boat design and the successful integration of energy and environmental goals within a defined operational marine context.

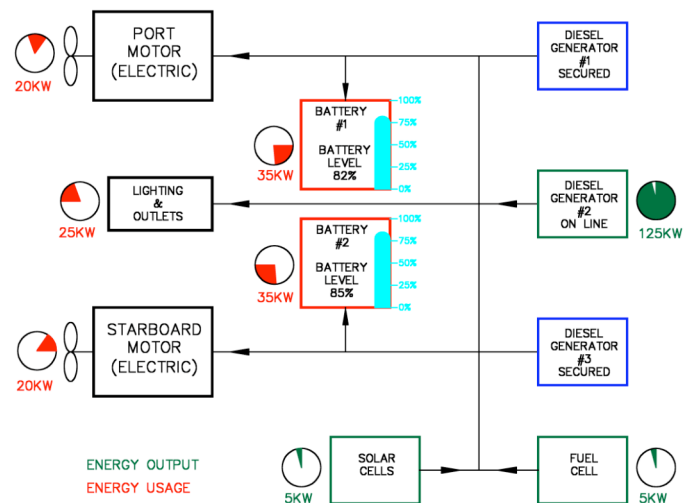

Propulsion System Team:

SIEMENS



ALION
SCIENCE AND TECHNOLOGY

Carnegie Mellon

